

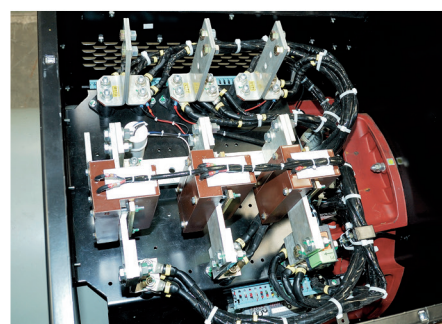

EMERSON[™]
Industrial Automation

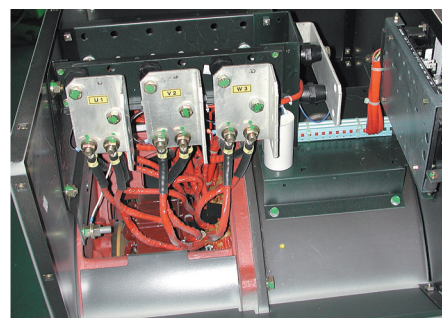
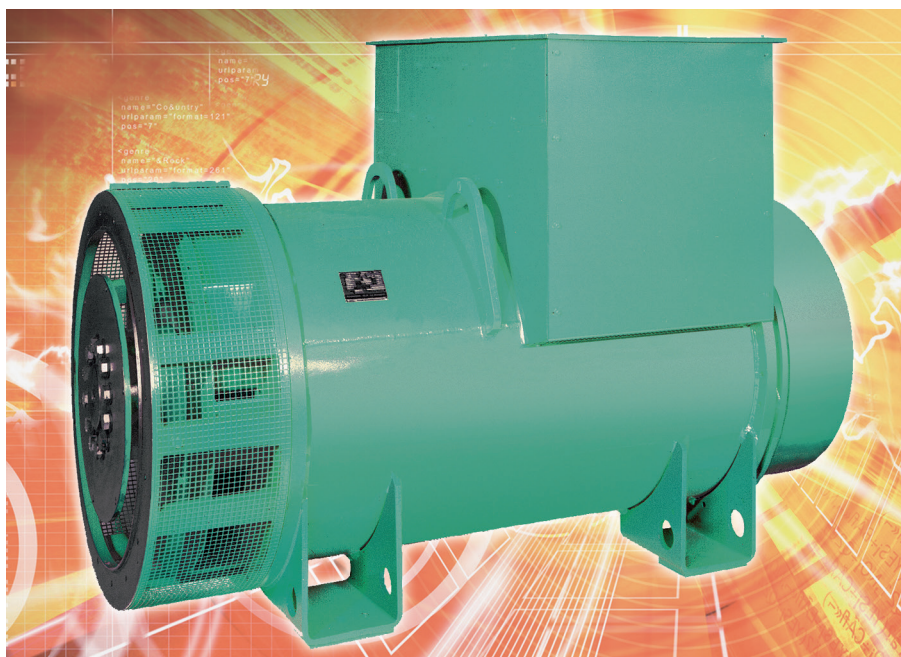

**LERROY[®]
SOMER**

Low Voltage alternators - 4 pole LSA 51.2

1860 to 2500 kVA - 50 Hz / 2235 to 3000 kVA - 60 Hz

Electrical and mechanical data

4164 en - 2014.01 / f

Low Voltage alternators 4 pole 3-phase

LSA 51.2

1860 to 2500 kVA - 50 Hz / 2235 to 3000 kVA - 60 Hz

SPECIALLY ADAPTED TO APPLICATIONS

The LSA 51.2 alternator is designed to be suitable for typical generator applications, such as: backup, marine applications, rental, telecommunications, etc.

COMPLIANT WITH INTERNATIONAL STANDARDS

The LSA 51.2 alternator conforms to the main international standards and regulations:

- IEC 60034, NEMA MG 1.32-33, ISO 8528-3, CSA / UL 1446 (UL 1004 on request), marine regulations, etc.

It can be integrated into a CE marked generator.

The LSA 51.2 is designed, manufactured and marketed in an ISO 9001 environment and ISO 14001.

TOP OF THE RANGE ELECTRICAL PERFORMANCE

- Class H insulation.
- Standard 6-wire winding, 2/3 pitch, type no. 6S.
- Voltage range 50 Hz: 380V - 400V - 415V - 440 V and 220V - 230V - 240V.
- Voltage range 60 Hz: 380V - 416V - 440V - 480V and 220 V - 240 V.
- High efficiency and motor starting capacity.
- Other voltages are possible with optional adapted windings:
 - 50 Hz : 440 V (no. 7S), 500 V (no. 9S), 600 V (no. 22S or 23S), 690 V (no. 10S or 52S).
 - 60 Hz : 380 V and 416 V (no. 8S), 600 V (no. 9S).
- R 791 interference suppression conforming to standard EN 55011 group 1 class B standard for European zone (CE marking).

EXCITATION AND REGULATION SYSTEM SUITED TO THE APPLICATION

The LSA 51.2 can be supplied with AREP or PMG excitation system, according to the alternator specification.

Standard excitation system is AREP with R 449 A.V.R.

Excitation system			Regulation options				
Volage regulator	AREP + PMI	PMG	Current transformer for paralleling	Mains paralleling	3-phase sensing	3-phase sensing for mains paralleling unbalanced	Remote voltage potentiometer
R449	Std	Option	C.T.	R726	R731	R734	√
D510C	Option	Option	C.T.	included	included	contact factory	√

Voltage regulator accuracy $\pm 0.5\%$ - √ : possible mounting

PROTECTION SYSTEM SUITED TO THE ENVIRONMENT

- The LSA 51.2 is IP 23.
- Standard winding protection for clean environments with relative humidity $\leq 95\%$, including indoor marine environments.
- Options :
 - Filters on air inlet : derating 5%.
 - Filters on air inlet and air outlet (IP 44) : derating 8%.
 - Winding protections for harsh environments and relative humidity greater than 95%.
 - Space heaters.
 - Thermal protection for winding.

REINFORCED MECHANICAL STRUCTURE USING FINITE ELEMENT MODELLING

- Compact and rigid assembly to better withstand generator vibrations.
- Steel frame.
- Cast iron flanges and shields.
- Twin-bearing and single-bearing versions designed to be suitable for engines on the market.
- Half-key balancing.
- Regreasable bearings.

ACCESSIBLE TERMINAL BOX PROPORTIONED FOR OPTIONAL EQUIPMENT

- Easy access to the voltage regulator and to the connections.
- Possible inclusion of accessories for paralleling, protection and measurement.

Low Voltage alternators 4 pole 3-phase

LSA 51.2

1860 to 2500 kVA - 50 Hz / 2235 to 3000 kVA - 60 Hz

General characteristics

Insulation class	H	Excitation system	AREP + PMI or PMG
Winding pitch	2/3 (n° 6S)	AVR type	R 449
Number of wires	6	Voltage regulation (*)	± 0.5 %
Protection	IP 23	Short-circuit current	300% (3 IN) : 10s
Altitude	≤ 1000 m	Totale Harmonic distortion THD (**)	< 4 %
Overspeed	2250 min ⁻¹	Waveform: NEMA = TIF (**)	< 50
Air flow	2.5 m ³ /s (50 Hz) - 2.8 m ³ /s (60 Hz)		

(*) Steady state. (**) Total harmonic distortion between phases, no-load or on-load (non-distorting)

Ratings 50 Hz - 1500 R.P.M.

kVA / kW - P.F. = 0.8																	
Duty/T°C		Continuous duty/40°C				Continuous duty/40°C				Stand-by/40°C				Stand-by/27°C			
Class/T°K		H/125°K				F/105°K				H/150°K				H/163°K			
Phase		3 ph.				3 ph.				3 ph.				3 ph.			
Y		380V	400V	415V	440V	380V	400V	415V	440V	380V	400V	415V	440V	380V	400V	415V	440V
Δ*		220V	230V	240V		220V	230V	240V		220V	230V	240V		220V	230V	240V	
LSA 51.2 S55	kVA	1860		1690		1700		1540		1955		1792		2045		1860	
	kW	1488		1352		1360		1232		1564		1433		1636		1488	
LSA 51.2 M60	kVA	2050		1864		1870		1700		2155		1975		2255		2050	
	kW	1640		1491		1496		1360		1724		1580		1804		1640	
LSA 51.2 L70	kVA	2200		2000		2005		1825		2330		2120		2420		2200	
	kW	1760		1600		1604		1460		1864		1696		1936		1760	
LSA 51.2 VL90	kVA	2360		2145		2150		1955		2500		2275		2595		2360	
	kW	1888		1716		1720		1564		2000		1820		2076		1888	
LSA 51.2 VL95	kVA	2500		2250		2280		2052		2650		2385		2750		2475	
	kW	2000		1800		1824		1642		2120		1908		2200		1980	

Δ* : Consult factory

Ratings 60 Hz - 1800 R.P.M.

kVA / kW - P.F. = 0.8																	
Duty/T°C		Continuous duty/40°C				Continuous duty/40°C				Stand-by/40°C				Stand-by/27°C			
Class/T°K		H/125°K				F/105°K				H/150°K				H/163°K			
Phase		3 ph.				3 ph.				3 ph.				3 ph.			
Y		380V	416V	440V	480V	380V	416V	440V	480V	380V	416V	440V	480V	380V	416V	440V	480V
Δ*		220V	240V			220V	240V			220V	240V			220V	240V		
LSA 51.2 S55	kVA	1860	2030	2150	2235	1695	1850	1960	2035	1955	2150	2280	2365	2045	2235	2365	2455
	kW	1488	1624	1720	1788	1356	1480	1568	1628	1564	1720	1824	1892	1636	1788	1892	1964
LSA 51.2 M60	kVA	2050	2240	2375	2460	1870	2045	2165	2250	2155	2375	2520	2608	2255	2465	2615	2705
	kW	1640	1792	1900	1968	1496	1636	1732	1800	1724	1900	2016	2086	1804	1972	2092	2164
LSA 51.2 L70	kVA	2200	2400	2545	2640	2005	2190	2320	2410	2330	2545	2700	2800	2420	2640	2800	2905
	kW	1760	1920	2036	2112	1604	1752	1856	1928	1864	2036	2160	2240	1936	2112	2240	2324
LSA 51.2 VL90	kVA	2360	2575	2730	2835	2150	2350	2490	2583	2500	2730	2895	3000	2595	2835	3005	3115
	kW	1888	2060	2184	2268	1720	1880	1992	2066	2000	2184	2316	2400	2076	2268	2404	2492
LSA 51.2 VL95	kVA	2500	2713	2870	3000	2280	2474	2617	2736	2650	2876	3042	3180	2750	2984	3157	3300
	kW	2000	2170	2296	2400	1824	1979	2093	2189	2120	2300	2433	2544	2200	2387	2525	2640

Δ* : Consult factory

Low Voltage alternators 4 pole 3-phase

LSA 51.2

1860 to 2500 kVA - 50 Hz / 2235 to 3000 kVA - 60 Hz

Efficiencies 50 Hz (— P.F.: 0.8) (----- P.F.: 1)

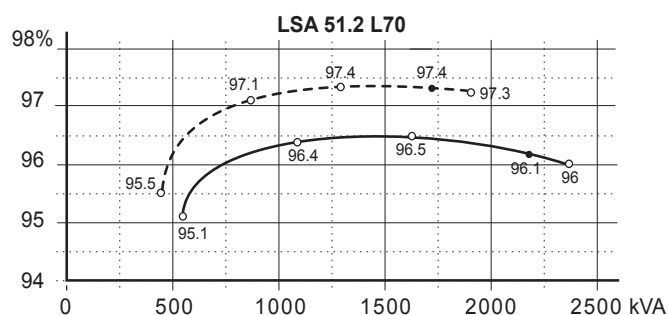
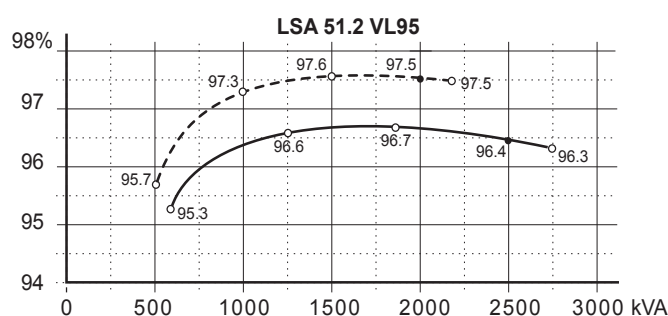
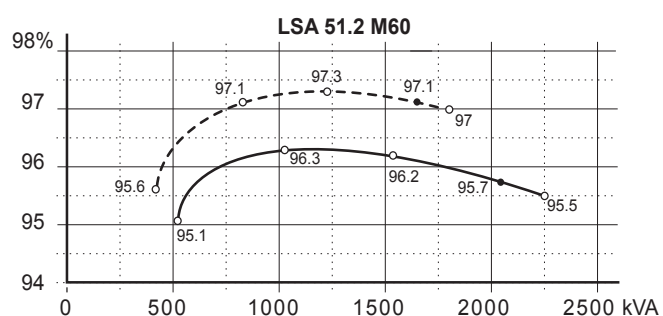
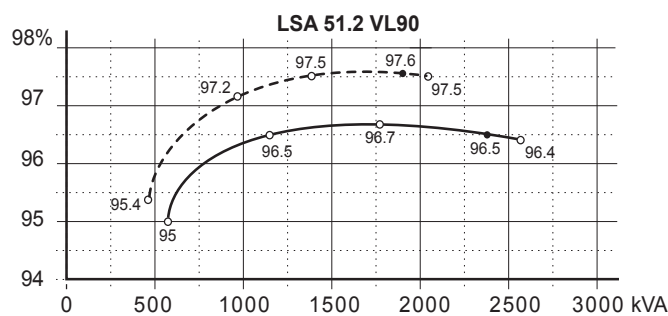
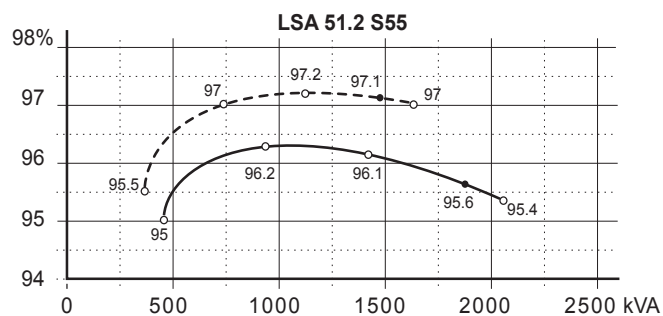

Reactances (%). Time constants (ms) - Class H / 400 V

	S55	M60	L70	VL90	VL95
Kcc Short-circuit ratio	0.33	0.36	0.39	0.44	0.39
Xd Direct-axis synchro. reactance unsaturated	367	350	321	287	311
Xq Quadrature-axis synchro. reactance unsaturated	220	210	193	172	187
T'do No-load transient time constant	2950	3080	3230	3390	3410
X'd Direct-axis transient reactance saturated	28.4	26.9	24.4	21.4	23.1
T'd Short-circuit transient time constant	268	278	288	298	299
X''d Direct-axis subtransient reactance saturated	14.8	13.9	12.7	11.1	12.1
T''d Subtransient time constant	22	23	24	26	26
X''q Quadrature-axis subtransient reactance saturated	18.4	17.5	15.9	13.9	15.0
Xo Zero sequence reactance unsaturated	2.6	2.5	2.2	2.0	2.1
X2 Negative sequence reactance saturated	16.7	15.7	14.3	12.5	13.6
Ta Armature time constant	39	41	45	49	49

Other class H/400 V data

	S55	M60	L70	VL90	VL95
io (A) No-load excitation current	1.3	1.4	1.4	1.4	1.3
ic (A) On-load excitation current	5.5	5.4	5.0	4.6	4.7
uc (V) On-load excitation voltage	58	57	53	49	50
ms Response time ($\Delta U = 20\%$ transient)	700	700	700	700	700
kVA Start ($\Delta U = 20\%$ cont. or 50% trans.)	3720	4100	4320	4500	5000
% Transient ΔU (on-load 4/4) - P.F.: 0.8 _{LAG}	13.1	12.5	11.4	10.2	10.9
W No-load losses	15300	16600	18200	20400	19300
W Heat dissipation	68000	73000	71000	68000	75000

Low Voltage alternators 4 pole 3-phase

LSA 51.2

1860 to 2500 kVA - 50 Hz / 2235 to 3000 kVA - 60 Hz

Transient voltage variation 400V - 50 Hz

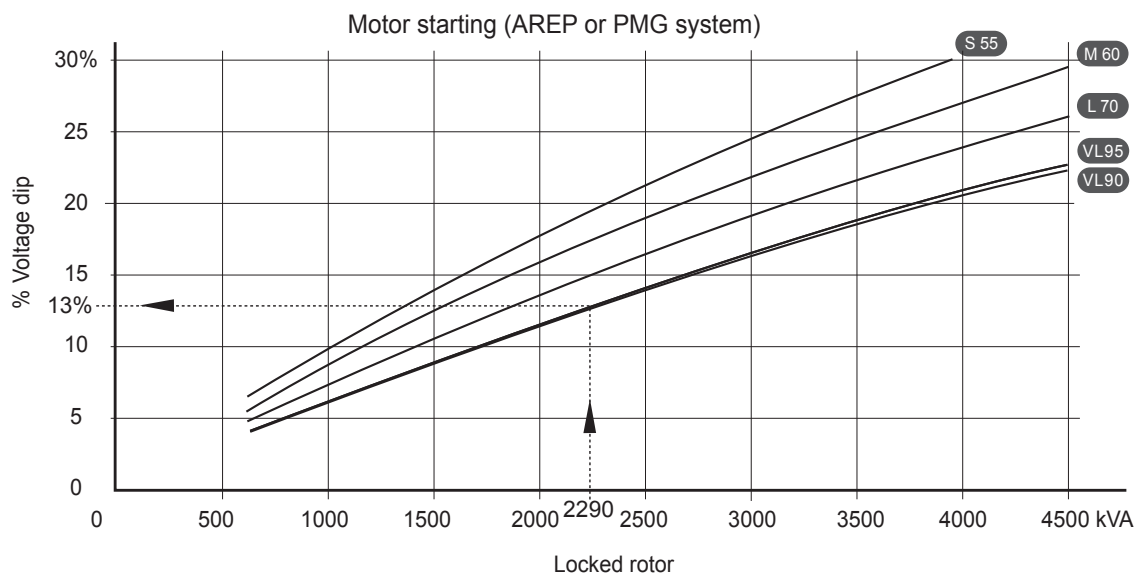
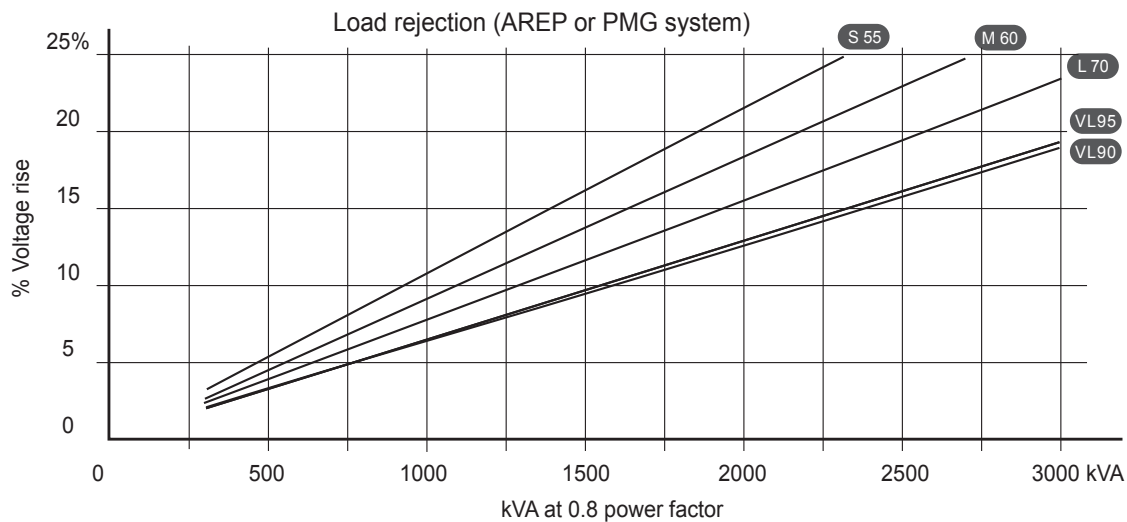
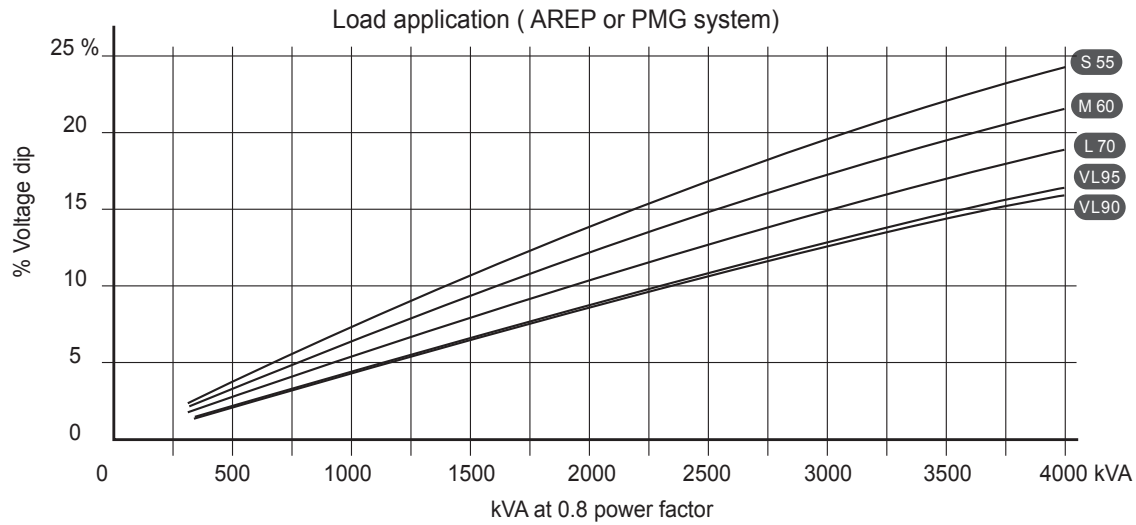

- For a starting P.F. other than 0.6, the starting kVA must be multiplied by $K = \text{Sine } \phi / 0.8$
 Calculation example for a different P.F. : Starter motor kVA calculated at 0.4 P.F. = 2000 kVA
 ► $\text{Sin } \phi 0.4 = 0.9165$ ► $K = 1.145$ ► kVA corrected = 2290 kVA ► Voltage dip corresponding to VL90 = 13 %.
- For voltages other than 400V (Y), 230V (Δ) at 50 Hz, then kVA must be multiplied by $(400/U)^2$ or $(230/U)^2$.

Low Voltage alternators 4 pole 3-phase

LSA 51.2

1860 to 2500 kVA - 50 Hz / 2235 to 3000 kVA - 60 Hz

Efficiencies 50 Hz (— P.F.: 0.8) (----- P.F.: 1)

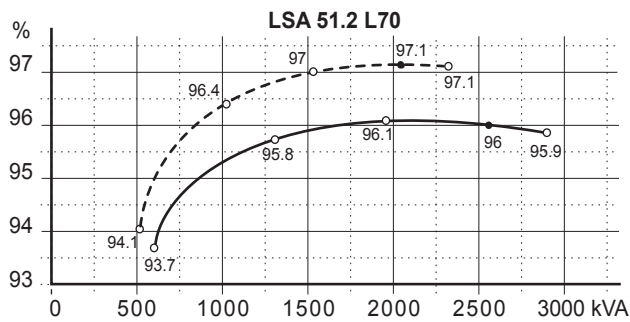
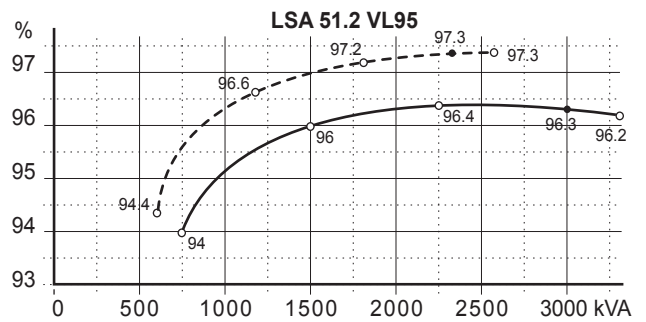
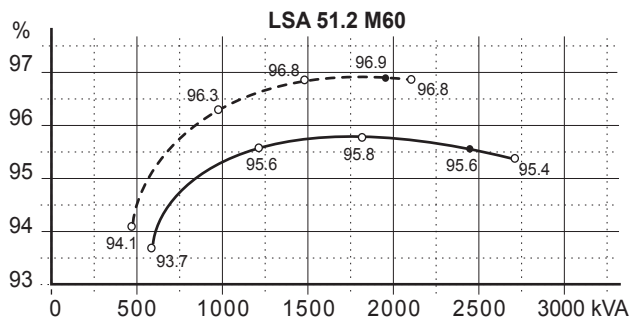
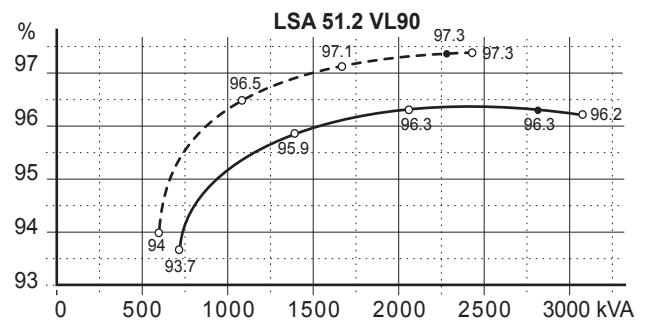
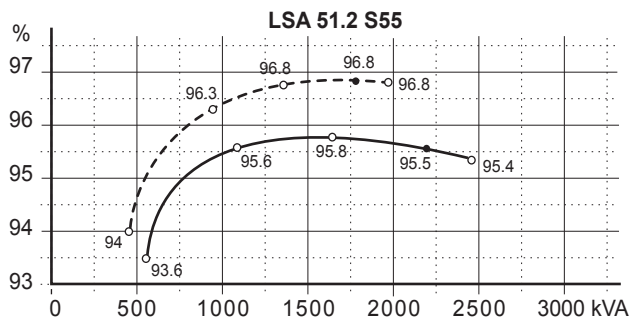

Reactances (%). Time constants (ms) - Class H / 480 V

	S55	M60	L70	VL90	VL95
Kcc Short-circuit ratio	0.33	0.36	0.39	0.44	0.39
Xd Direct-axis synchro. reactance unsaturated	368	350	321	287	311
Xq Quadrature-axis synchro. reactance unsaturated	221	210	193	172	187
T'do No-load transient time constant	2950	3080	3230	3390	3410
X'd Direct-axis transient reactance saturated	28.4	26.9	24.4	21.4	23.1
T'd Short-circuit transient time constant	268	278	288	298	299
X''d Direct-axis subtransient reactance saturated	14.8	13.9	12.7	11.1	12.1
T''d Subtransient time constant	22	23	24	26	26
X''q Quadrature-axis subtransient reactance saturated	18.5	17.5	15.9	13.9	15.0
Xo Zero sequence reactance unsaturated	2.6	2.5	2.2	2.0	2.1
X2 Negative sequence reactance saturated	16.7	15.7	14.3	12.6	13.6
Ta Armature time constant	39	41	45	49	49

Other class H/480 V data

io (A) No-load excitation current	1.3	1.4	1.4	1.4	1.3
ic (A) On-load excitation current	5.5	5.4	5.0	4.6	4.7
uc (V) On-load excitation voltage	59	57	53	49	50
ms Response time ($\Delta U = 20\%$ transient)	700	700	700	700	700
kVA Start ($\Delta U = 20\%$ cont. or 50% trans.)	4460	4920	5180	5400	6000
% Transient ΔU (on-load 4/4) - P.F.: 0.8 _{LAG}	13.1	12.5	11.4	10.2	10.9
W No-load losses	27100	28800	31100	34200	32000
W Heat dissipation	83000	91000	89000	87000	92000

Low Voltage alternators 4 pole 3-phase

LSA 51.2

1860 to 2500 kVA - 50 Hz / 2235 to 3000 kVA - 60 Hz

Transient voltage variation 480V - 60 Hz

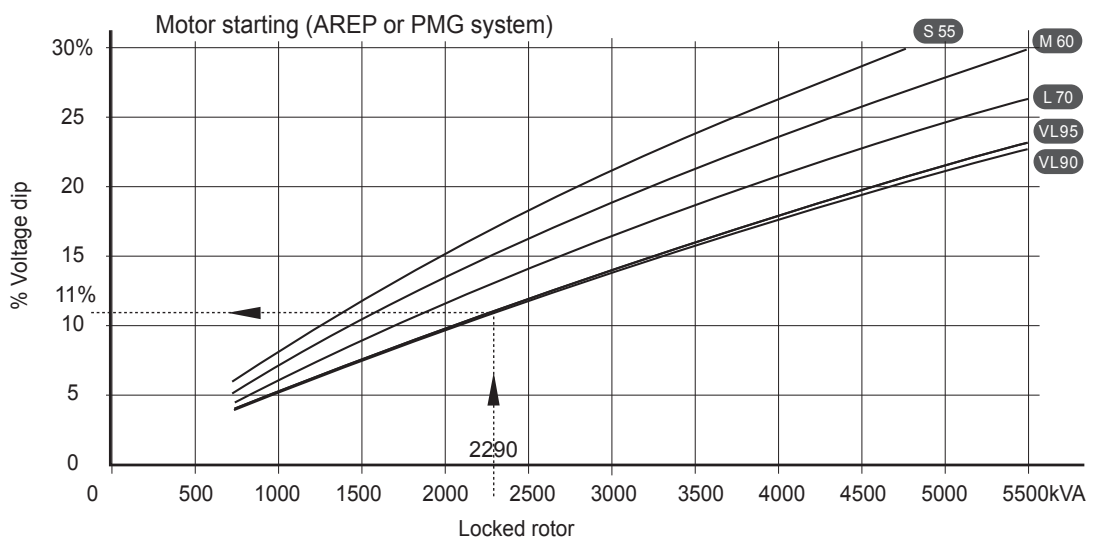
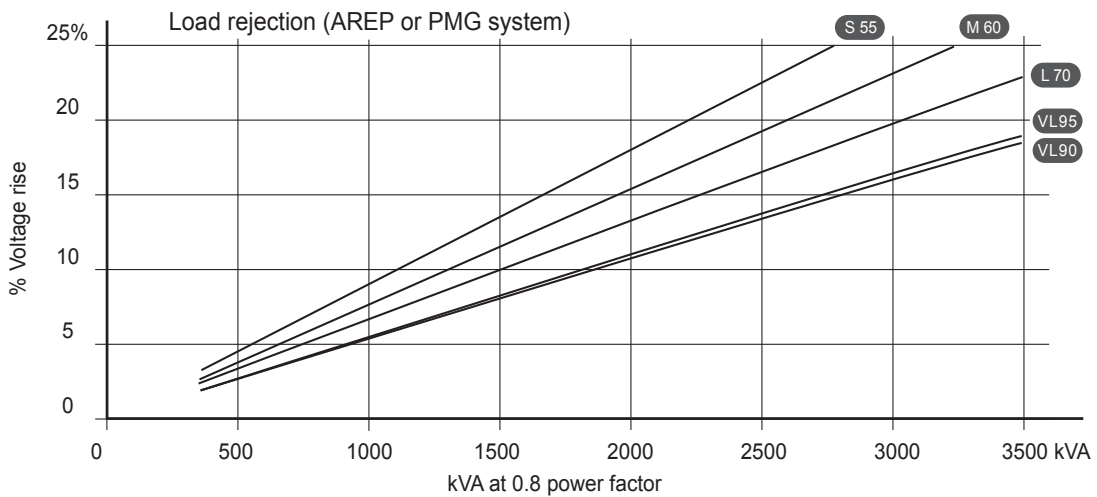
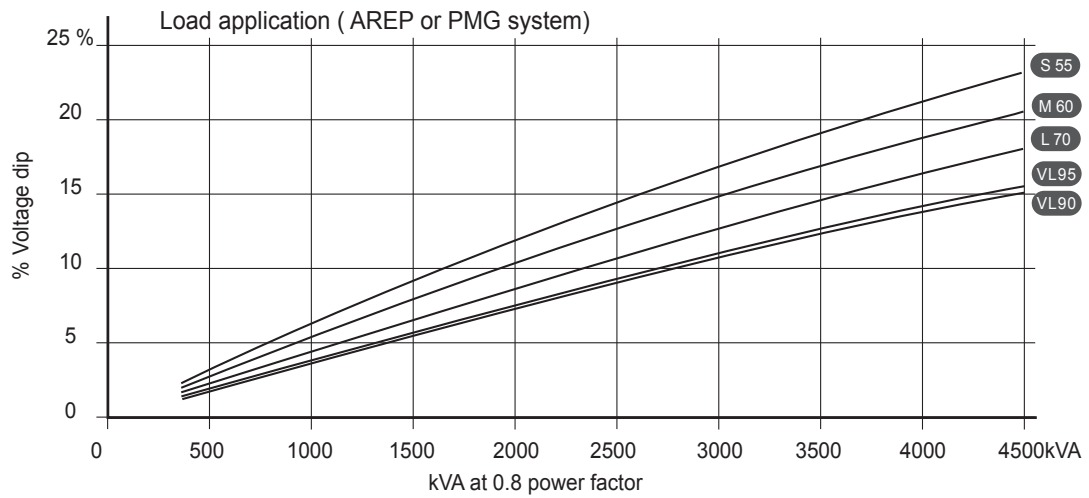

- 1) For a starting P.F. other than 0.6, the starting kVA must be multiplied by $K = \text{Sine } \phi / 0.8$
 Calculation example for a different P.F. : Starter motor kVA calculated at 0.4 P.F. = 2000 kVA
 $\blacktriangleright \text{Sin } \phi 0.4 = 0,9165 \blacktriangleright K = 1.145 \blacktriangleright \text{kVA corrected} = 2290 \text{ kVA} \blacktriangleright \text{Voltage dip corresponding to VL90} = 11 \%$
- 2) For voltages other than 480V (Y), 277V (Δ), 240V (YY) at 60 Hz ,
 then kVA must be multiplied by $(480/U)^2$ or $(277/U)^2$ or $(240/U)^2$.

Low Voltage alternators 4 pole 3-phase

LSA 51.2

1860 to 2500 kVA - 50 Hz / 2235 to 3000 kVA - 60 Hz

3-phase short-circuit curves at no load and rated speed (star connection Y)

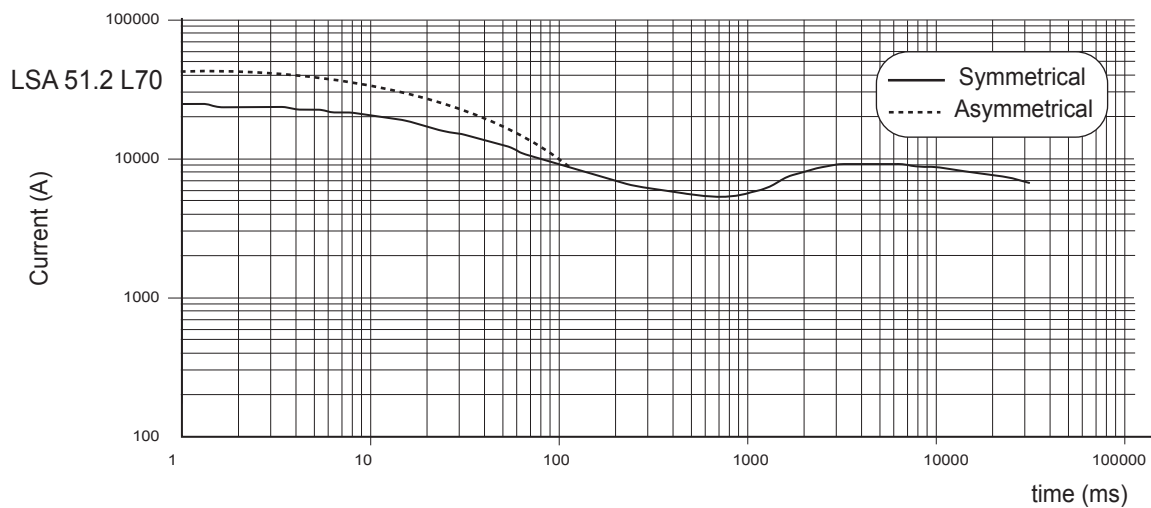
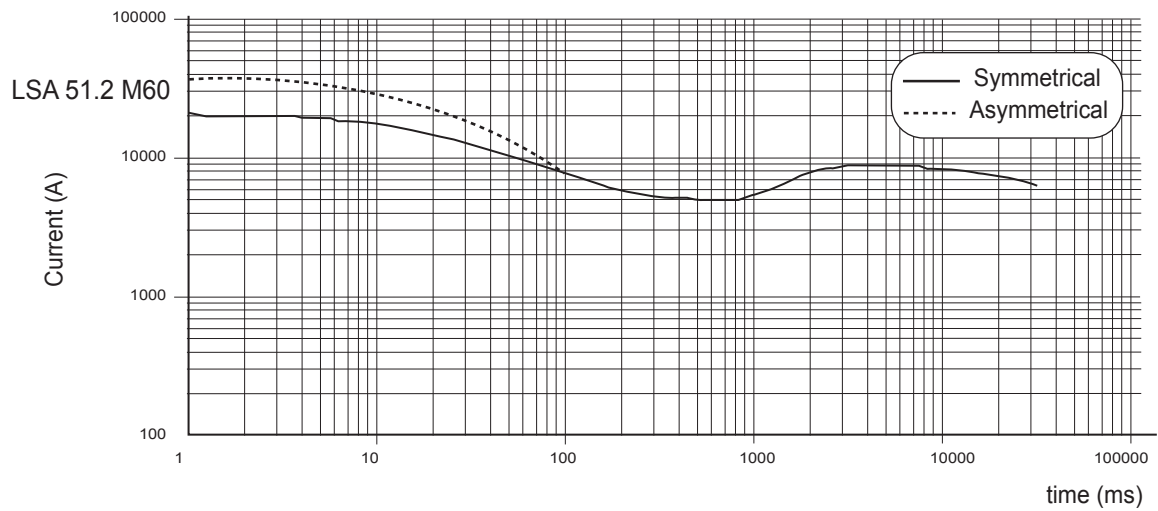
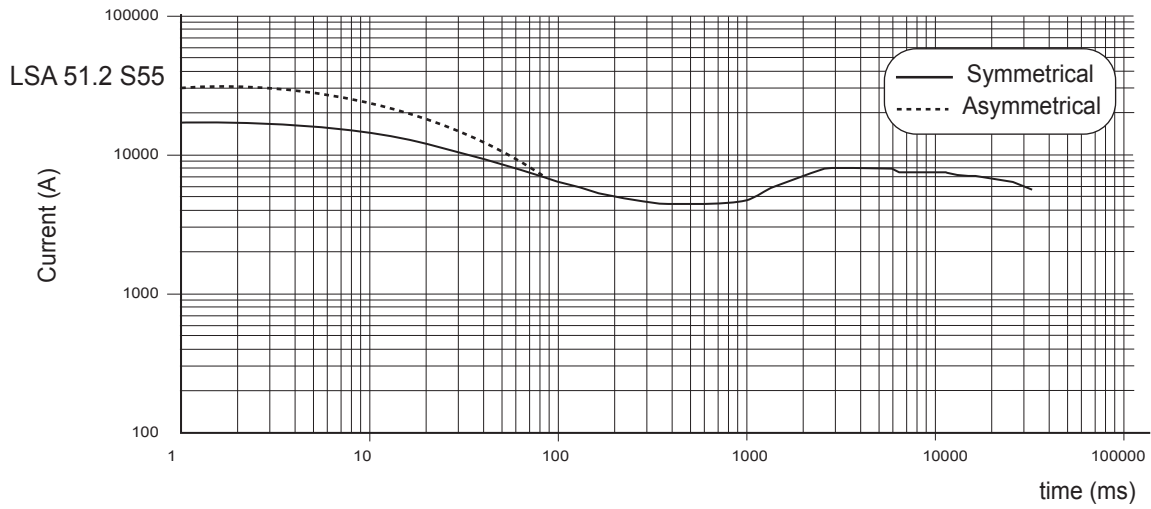

Influence due to connection

Curves shown are for star (Y) connection.

For other connections, use the following multiplication factors:

- Series delta : current value x 1.732 - Parallel star : current value x 2

Low Voltage alternators 4 pole 3-phase

LSA 51.2

1860 to 2500 kVA - 50 Hz / 2235 to 3000 kVA - 60 Hz

3-phase short-circuit curves at no load and rated speed (star connection Y)

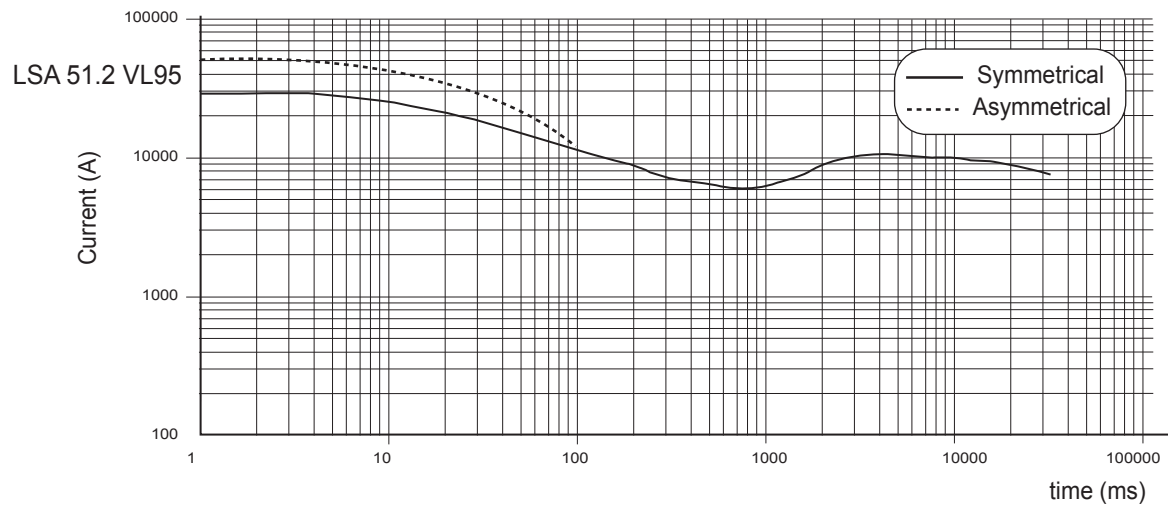
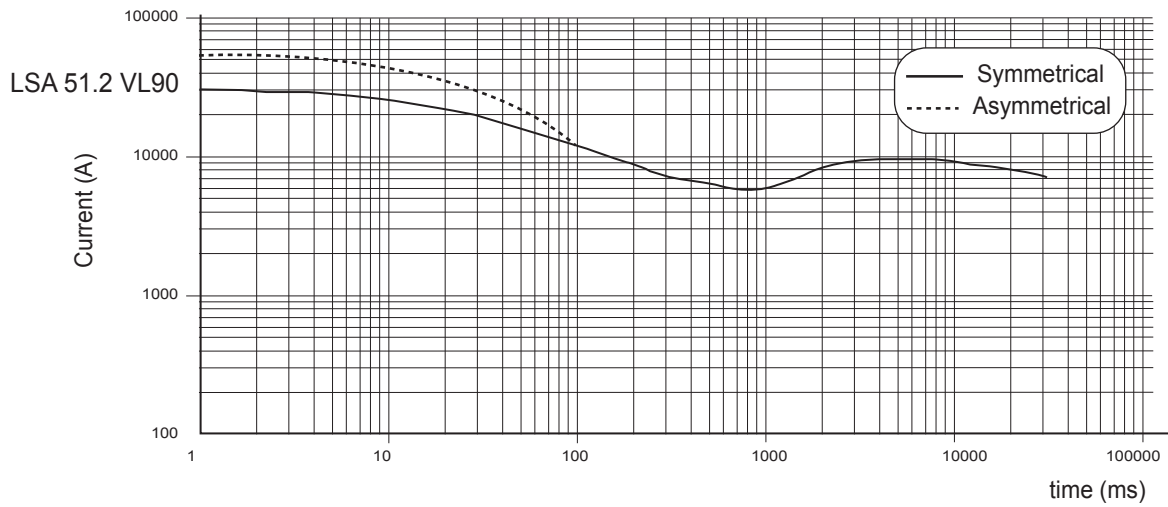

Influence due to short-circuit

Curves are based on a three-phase short-circuit.

For other types of short-circuit, use the following multiplication factors.

	3-phase	2-phase L/L	1-phase L/N
Instantaneous (max.)	1	0.87	1.3
Continuous	1	1.5	2.2
Maximum duration (AREP/PMG)	10 sec.	5 sec.	2 sec.

Low Voltage alternators 4 pole 3-phase

LSA 51.2

1860 to 2500 kVA - 50 Hz / 2235 to 3000 kVA - 60 Hz

Single bearing dimensions

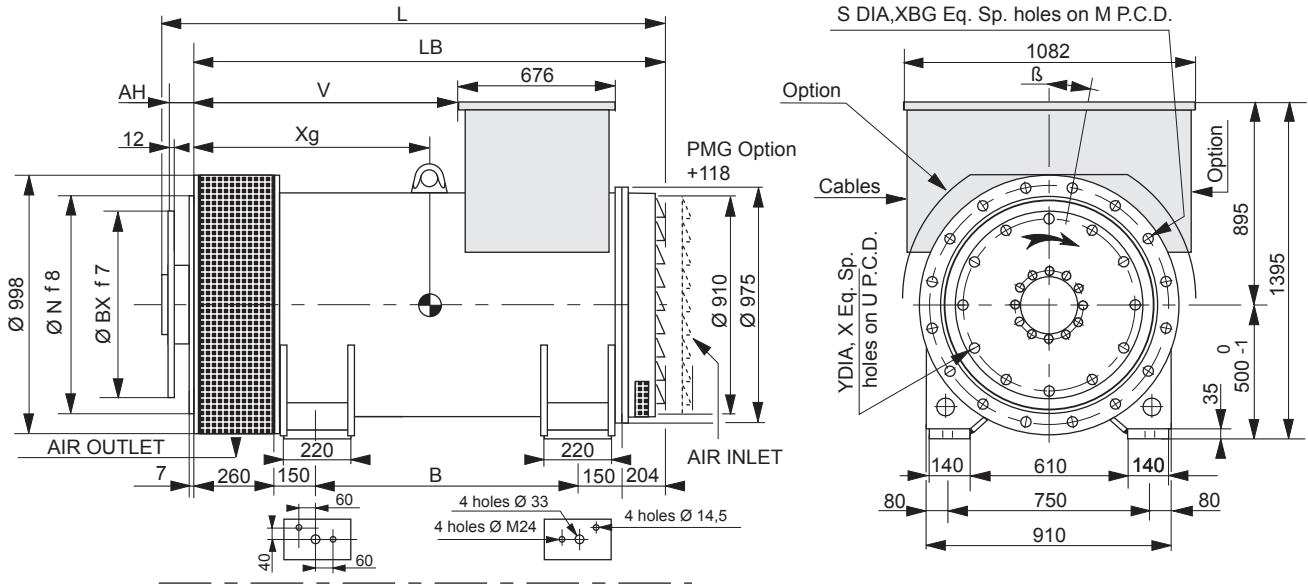

Dimensions (mm) and weight							Coupling		
Type	L without PMG	LB	B	V	Xg	Weight (kg)	Flex plate		
LSA 51.2 S55	1699	1677	900	744	735	3745	0	00	
LSA 51.2 M60	1799	1777	1000	844	770	4040			X
LSA 51.2 L70	1899	1877	1100	944	825	4445			X
LSA 51.2 VL90	1999	1977	1200	1044	885	4995			X
LSA 51.2 VL95	1999	1977	1200	1044	890	5065	X		X

Flange (mm)						Flex plate (mm)					
S.A.E.	N	M	XBG	S	β°	S.A.E.	BX	U	X	Y	AH
0	647.7	679.5	16	14	11°15'	24	733.4	692.1	12	21	0
00	787.4	850.9	16	14	11°15'	21	673.1	641.3	12	18	0
						18	571.5	542.9	6	18	15.8

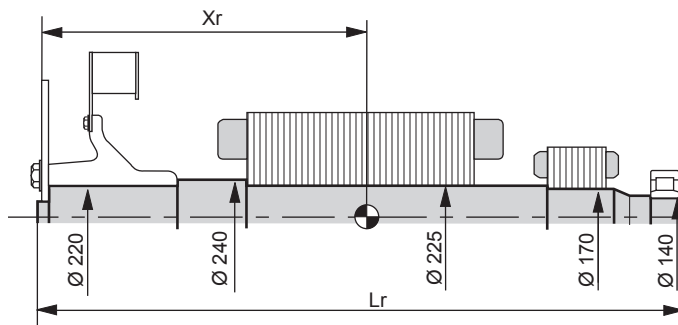

Torsional analysis data

Centre of gravity: Xr (mm), Rotor length: Lr (mm), Weight: M (kg), Moment of inertia: J (kgm²): (4J = MD²)												
Type	Flex plate S.A.E. 18				Flex plate S.A.E. 21				Flex plate S.A.E. 24			
	Xr	Lr	M	J	Xr	Lr	M	J	Xr	Lr	M	J
LSA 51.2 S55	661	1555.5	1357	41.1	643	1555.5	1359	41.9	640	1555.5	1365	42.6
LSA 51.2 M60	703	1655.5	1475	44.8	685	1655.5	1479	45.6	682	1655.5	1483	46.3
LSA 51.2 L70	754	1755.5	1630	50	736	1755.5	1632	50.8	734	1755.5	1638	51.6
LSA 51.2 VL90	819	1855.5	1833	57.2	801	1855.5	1835	58	799	1855.5	1841	58.8
LSA 51.2 VL95	821	1855.5	1854	63.7	805	1855.5	1854	64.4	802	1855.5	1860	65.2

NOTE : Dimensions are for information only and may be subject to modifications. Contractuel 2D drawings can be downloaded from the Leroy-Somer site, 3D drawing files are available upon request.

Low Voltage alternators 4 pole 3-phase

LSA 51.2

1860 to 2500 kVA - 50 Hz / 2235 to 3000 kVA - 60 Hz

Two bearing dimensions

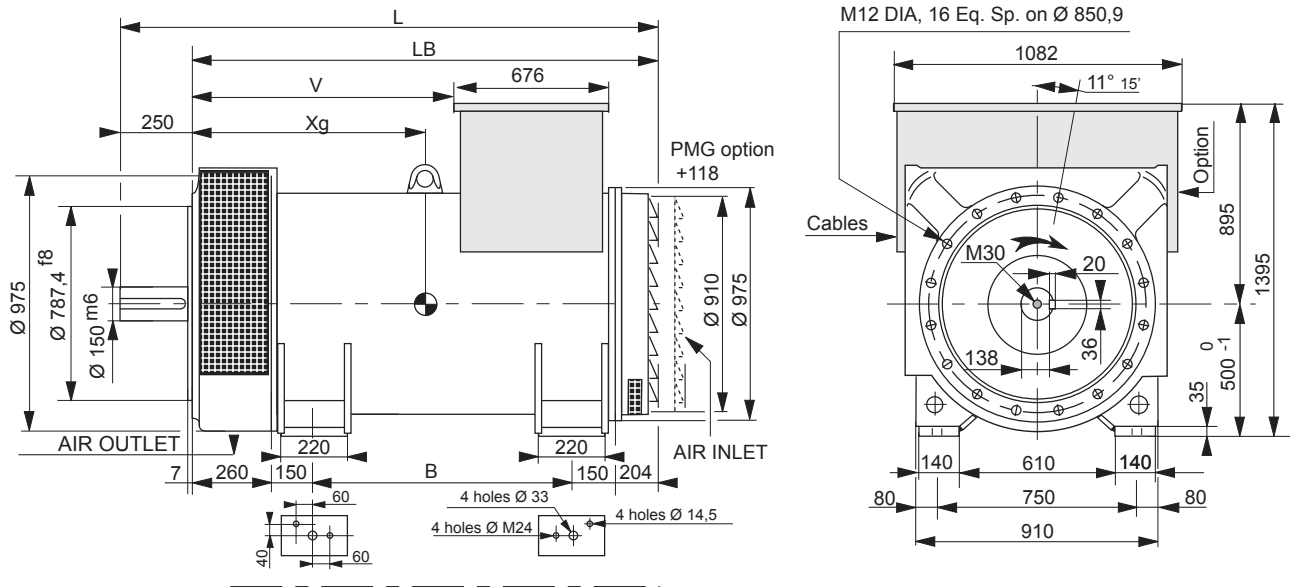

Dimensions (mm) and weight

Type	L without PMG	LB	B	V	Xg	Weight (kg)
LSA 51.2 S55	1905	1655	900	744	735	3725
LSA 51.2 M60	2005	1755	1000	844	770	4020
LSA 51.2 L70	2105	1855	1100	944	825	4425
LSA 51.2 VL90	2205	1955	1200	1044	885	4975
LSA 51.2 VL95	2205	1955	1200	1044	890	5045

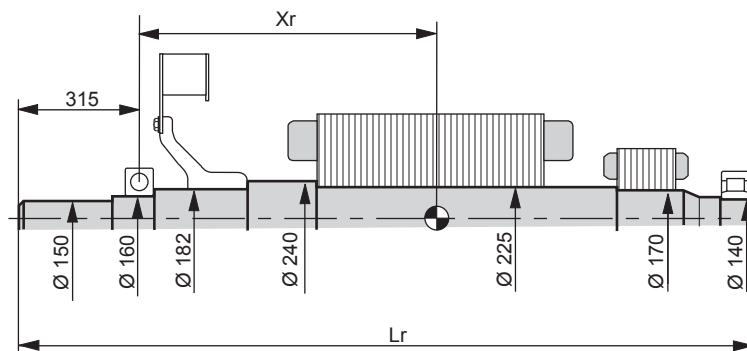

Torsional analysis data

Centre of gravity: Xr (mm), Rotor length: Lr (mm), Weight: M (kg), Moment of inertia: J (kgm²): (4J = MD²)

Type	Xr	Lr	M	J
LSA 51.2 S55	610.8	1783.5	1289	40
LSA 51.2 M60	652.6	1883.5	1406	43.8
LSA 51.2 L70	703.7	1983.5	1561	49
LSA 51.2 VL90	767.5	2083.5	1763	56.3
LSA 51.2 VL95	793.2	2083.5	1789	61.7

NOTE : Dimensions are for information only and may be subject to modifications. Contractuel 2D drawings can be downloaded from the Leroy-Somer site, 3D drawing files are available upon request.

Contact

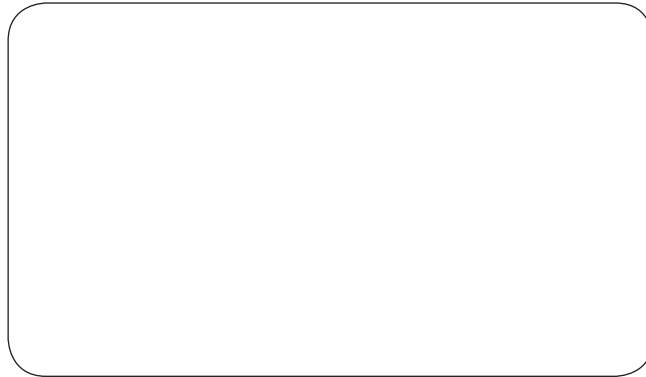

www.leroy-somer.com



**LEROY
SOMER**

EMERSON
Industrial Automation

© - This document is the property of Moteurs Leroy-Somer, it can not be reproduced in any form without prior written authorization.
Moteurs Leroy-Somer reserves the right to modify the design, technical specifications and dimensions of the products shown in this document.
The descriptions cannot in any way be considered contractual.

Moteurs Leroy-Somer SAS - RCS 338 567 258 ANGOULÊME - Capital de 65 800 512 €